

Lumber Melamine Hardwood Plywood Archite  
ctural Panels Colored Caulk Particle Board E  
xotic Lumber MDF Veneer Moulding Laminat  
es Hardware Edgeband Adhesives Bendable  
Panels Lumber Melamine Hardwood Plywood



Panels Lumber Melamine Hardwood Plywood  
Architectural Panels Colored Caulk Particle



# The Incomparable Beauty of Hardwood Mouldings

Hardwood moulding is the ideal finishing touch for cabinets, furniture and residential and commercial spaces. Moulding adds style, polish and sophistication to every project. While we offer a selection of stock profiles in red oak, poplar, maple and mahogany, we can accommodate your custom order in a broad variety of domestic and exotic species. We cut our own knives and are continually adding to our collection of more than 1000 patterns.



In addition to the hundreds of hardwood profiles we offer, we also offer a veneer-wrapped alternative to traditional hardwood moulding. Our goal is to provide profile and species options to meet even your most ambitious architectural and design needs, including innovative, technologically advanced products, such as veneer-wrapped mouldings. Please see page 60 for information about our veneer-wrapped moulding products.

Please contact the distribution center in your area for custom orders or to inquire about species available.

A limited selection of domestic and imported species are available as FSC-certified. Please contact a sales representative at the distribution center in your area for more information about FSC-certified products.



For assistance with products which may help you meet LEED requirements, refer to the chart on page three or contact your Hardwoods Incorporated sales representative.



Forest Stewardship Council  
(FSC)-certified products  
available upon request.

SGSNA-COC-2185

© 1996 Forest Stewardship Council A.C.

# MOULDINGS

At Hardwoods Incorporated, we know that you are buying more than moulding when you select our products. You're choosing exceptional quality, professional expertise, and decades of manufacturing experience.

We specialize in serving the needs of architects and designers, custom cabinet makers, fixture manufacturers, builders and homeowners. Hardwoods Incorporated has one of the largest inventories of specialty hardwoods and related products in the Southeast. We carry our commitment to excellence to extraordinary levels with a fully integrated process that allows us to control quality from rough green lumber through the drying and manufacturing process, to sales in our distribution centers. This highly integrated production process affords us the ability to price our mouldings competitively while delivering the highest quality mouldings and services in the market.

More than a million linear feet of mouldings are produced each month at our Cleveland, GA, facility from a variety of hardwood species, including ash, basswood, birch, cherry, hickory, mahogany, poplar, hard maple, soft maple, red oak, white oak and walnut. All of the Appalachian hardwoods used to mill our moulding products are processed through company-owned dry kilns.

Each of our distribution centers stocks a variety of moulding products. If the moulding you prefer is not in inventory at the distribution center near you, it can be ordered for delivery within days.

Please see page 12 for S4S hardwoods.



## STOCK MOULDINGS

We stock a complete line of hardwood mouldings in a variety of species including, ash, basswood, birch, cherry, hickory, mahogany, poplar, hard maple, soft maple, red oak, white oak and walnut. Contact your local distribution center for product availability.

## CUSTOM MOULDINGS

Custom mouldings are also available upon request. Orders for custom mouldings often can be filled within a 10-day period. Please call the distribution center in your area for current lead times. Please refer to the lumber section of this catalogue, page 9 for Millwork Services.



## Crown Mouldings

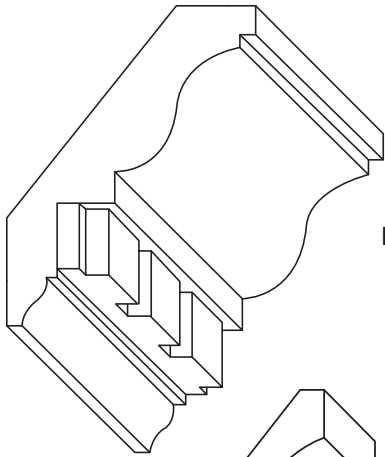

Crown  
WCM7  
1-1/16 x 5-9/16  
Dentil  
WCM707  
1 1/16 x 15/16

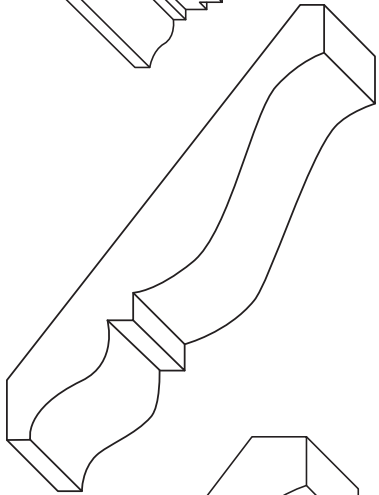

8" Crown  
WCM9  
1-1/16 x 7-9/16

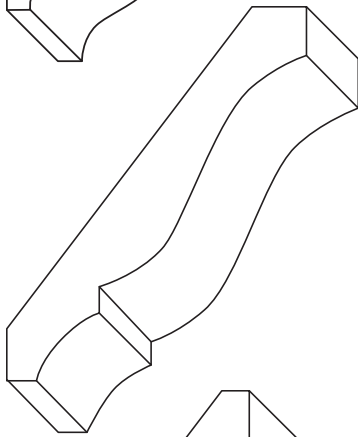

7" Crown  
WCM15  
1-1/16 x 6-1/2

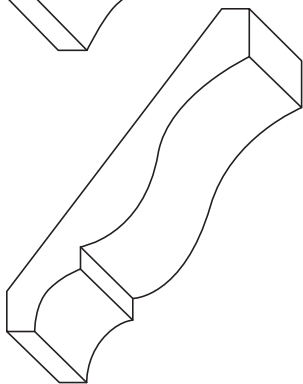

6" Crown  
WCM17  
1 1/16 x 5-5/8

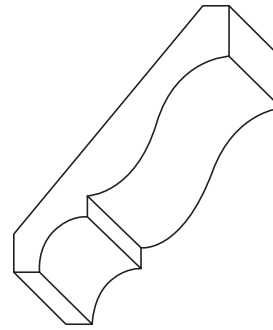

5" Crown  
WCM47  
1 1/16 x 4-5/8

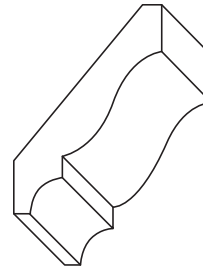

4" Crown  
WCM49  
9/16 x 3-5/8

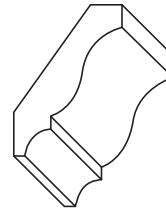

3" Crown  
WCM52  
9/16 x 2-5/8

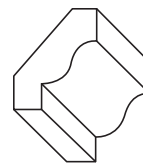

2" Crown  
WCM60  
9/16 x 1-3/4

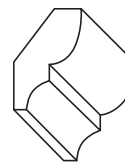

2" Crown  
WCM74  
9/16 x 1-3/4

Moulding illustrations in this section are not depicted to actual size. Please contact the distribution center in your area for a more extensive selection of moulding profiles. For downloadable, scalable files of moulding profiles that can be reproduced at actual size, please visit our Web site at [www.hardwoodweb.com](http://www.hardwoodweb.com).

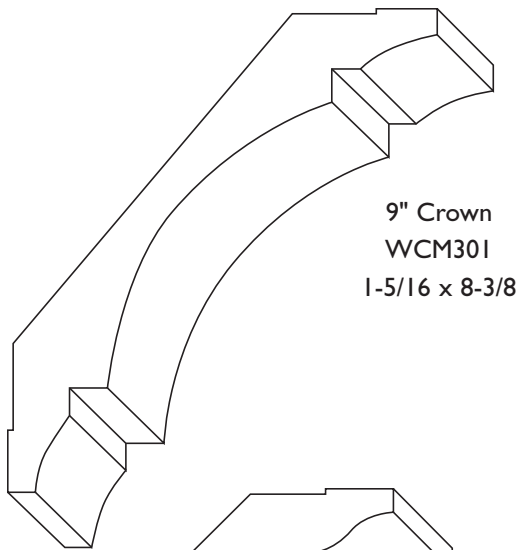

9" Crown  
WCM301  
1-5/16 x 8-3/8

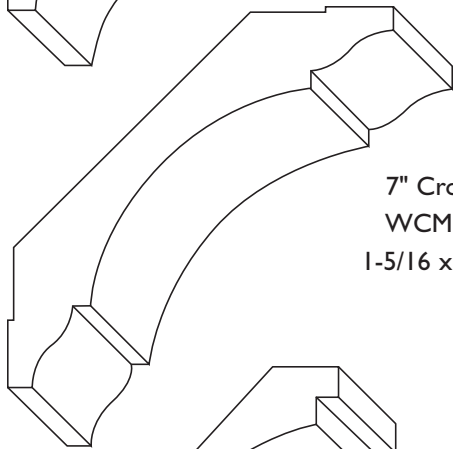

7" Crown  
WCM375  
1-5/16 x 6-5/8

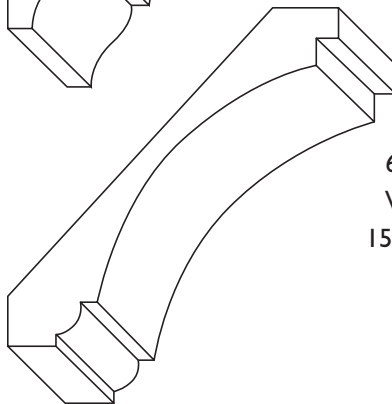

6" Crown  
WCM325  
15/16 x 5-7/8

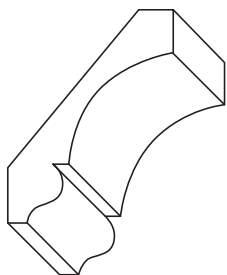

4" Crown  
WCM309  
3/4 x 3-11/16

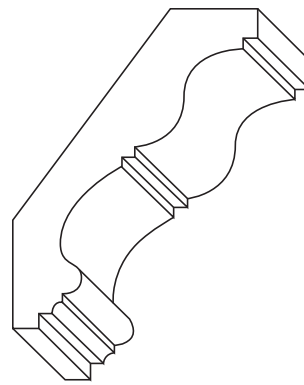

6" Crown  
WCM346  
1-1/4 x 5-9/16

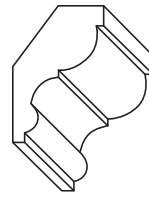

3" Crown  
WCM339  
3/4 x 2-3/8

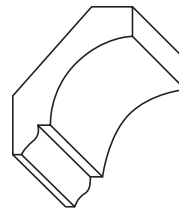

3" Crown  
WCM317  
11/16 x 2-9/16

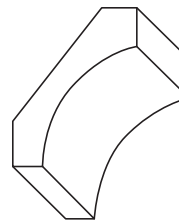

3" Crown  
WCM370  
23/32 x 2-3/4

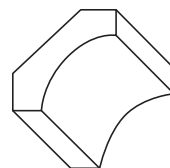

2" Crown  
WCM85  
9/16 x 1-3/4

Moulding illustrations in this section are not depicted to actual size. Please contact the distribution center in your area for a more extensive selection of moulding profiles. For downloadable, scalable files of moulding profiles that can be reproduced at actual size, please visit our Web site at [www.hardwoodweb.com](http://www.hardwoodweb.com).

## Casings

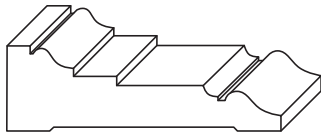

5" Casing  
WCM591  
1-1/2 x 4-3/4

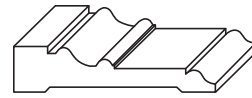

4" Casing  
WCM573  
13/16 x 3-1/2

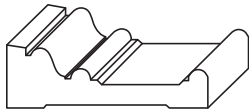

4" Casing  
WCM3  
1-1/16 x 3-1/2



3" Casing  
WCM351  
11/16 x 2-1/2

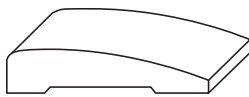

4" Casing  
WCM326  
3/4 x 3-1/2



3" Casing  
WCM356  
11/16 x 2-1/4

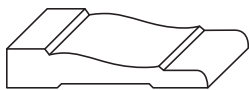

4" Casing  
WCM344  
3/4 x 3-1/2



3" Casing  
WCM366  
11/16 x 2-1/4

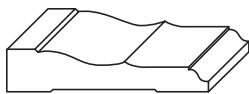

4" Casing  
WCM345  
3/4 x 3-1/2

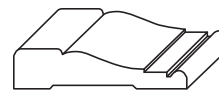

3" Casing  
WCM371  
11/16 x 3

Moulding illustrations in this section are not depicted to actual size. Please contact the distribution center in your area for a more extensive selection of moulding profiles. For downloadable, scalable files of moulding profiles that can be reproduced at actual size, please visit our Web site at [www.hardwoodweb.com](http://www.hardwoodweb.com).



3" Casing  
WCM711  
5/8 x 2-1/4

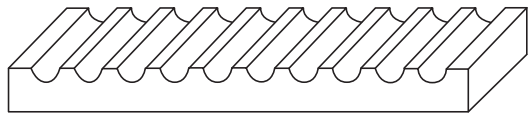

8" Fluted Casing  
WCM719  
3/4 x 8



4" Fluted Casing  
WCM726  
3/4 x 3-7/8

## Back Bands

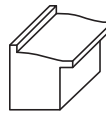

Back Band  
WCM200  
1-3/16 x 1-1/8

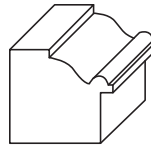

Back Band  
WCM207  
1-1/2 x 1-5/8



Back Band  
WCM280  
1 1/16 x 1-1/16

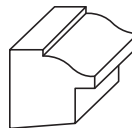

Back Band  
WCM281  
1-5/16 x 1-3/8

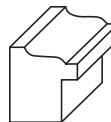

Back Band  
WCM282  
1-3/16 x 1-5/16



Back Band  
WCM288  
1-1/16 x 1-1/2

Moulding illustrations in this section are not depicted to actual size. Please contact the distribution center in your area for a more extensive selection of moulding profiles. For downloadable, scalable files of moulding profiles that can be reproduced at actual size, please visit our Web site at [www.hardwoodweb.com](http://www.hardwoodweb.com).

## Mull Casings & Aprons

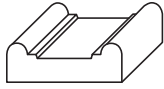

Mull Casing  
WCM22-2  
1 1/16 x 2

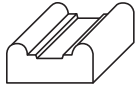

Mull Casing  
WCM22-1-1/2  
1 1/16 x 1-1/2

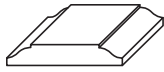

Mull Casing  
WCM987-2  
3/8 x 2



Mull Casing  
WCM987-1-1/2  
3/8 x 1-1/2



Apron  
WCM2  
23/32 x 2-1/2

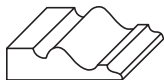

Apron  
WCM313  
9/16 x 2

## Base Mouldings



Base Mould  
WCM637  
3/4 x 6-1/2



Base Mould  
WCM609  
3/4 x 6-1/4

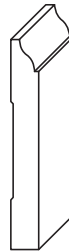

Base Mould  
WCM624  
9/16 x 4-1/4

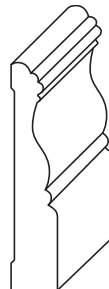

Base Mould  
WCM504  
13/16 x 3-15/16

Moulding illustrations in this section are not depicted to actual size. Please contact the distribution center in your area for a more extensive selection of moulding profiles. For downloadable, scalable files of moulding profiles that can be reproduced at actual size, please visit our Web site at [www.hardwoodweb.com](http://www.hardwoodweb.com).

## Base Caps, Shoes and Quarter-Rounds

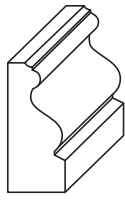

2-1/4" Base Cap  
WCM579  
1 x 2-1/4

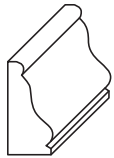

2" Base Cap  
WCM664  
3/4 x 1-5/8



Base Cap  
WCM163  
1 1/16 x 1-3/8

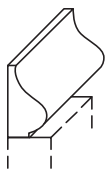

Base Cap  
WCM166  
1 1/16 x 1-1/4

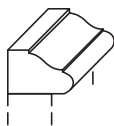

Base Cap  
WCM5  
3/4 x 1-1/8

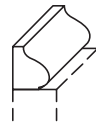

Base Cap  
WCM172  
5/8 x 3/4



Base Cap  
WCM174  
1/2 x 3/4



Shoe Mould  
WCM31  
1/2 x 3/4



Shoe Mould  
WCM127  
7/16 x 1 1/16



Quarter Round  
WCM106  
1/2 x 1/2

Moulding illustrations in this section are not depicted to actual size. Please contact the distribution center in your area for a more extensive selection of moulding profiles. For downloadable, scalable files of moulding profiles that can be reproduced at actual size, please visit our Web site at [www.hardwoodweb.com](http://www.hardwoodweb.com).

**Chair Rail**



Chair Rail  
WCM1001  
23/32 x 2-3/4



Chair Rail  
WCM297  
1-1/32 x 3-9/16



Chair Rail  
WCM417  
1-1/8 x 3-1/8

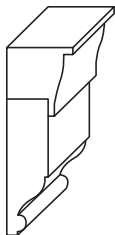

Back Band  
WCM200  
1 3/16 x 1-1/8

Chair Rail  
WCM501  
11/16 x 2-3/8

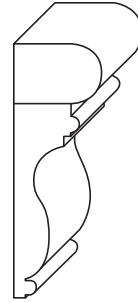

Mantle Mould  
WCM505  
1-1/8 x 3-3/8

Chair Rail  
WCM205  
1 x 1-1/2

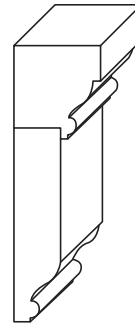

Back Band  
WCM207  
1-1/2 x 1-3/8

Chair Rail  
WCM504  
13/16 x 3-3/8

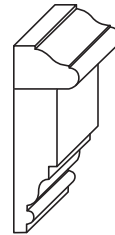

Back Band  
WCM5  
3/4 x 1-1/8

Chair Rail  
WCM2  
23/32 x 2-1/2

Moulding illustrations in this section are not depicted to actual size. Please contact the distribution center in your area for a more extensive selection of moulding profiles. For downloadable, scalable files of moulding profiles that can be reproduced at actual size, please visit our Web site at [www.hardwoodweb.com](http://www.hardwoodweb.com).

## Panel Mouldings

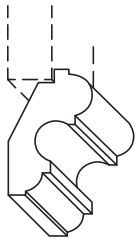

Panel Mould  
WCM8503  
1-7/16 x 2-3/16



Panel Mould  
WCM151  
1-1/4 x 2-1/8



Panel Mould  
WCM8500  
1 x 1-7/8

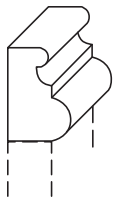

Panel Mould  
WCM42  
1-1/16 x 1-5/8



Panel Mould  
WCM42-3/4  
1-1/16 x 1-5/8

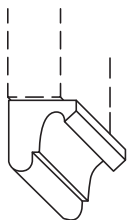

Panel Mould  
WCM8504  
3/4 x 1-1/4

## Stops

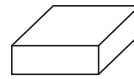

Stop  
WCM932  
1/2 x 1-1/2



Stop  
WCM934  
1/2 x 2

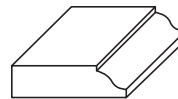

Stop  
WCM936  
1/2 x 2

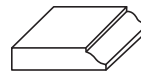

Stop  
WCM935  
3/8 x 1-5/8

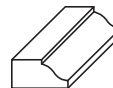

Stop  
WCM941  
1/2 x 1-1/2



Stop  
WCM940  
3/8 x 7/8

Moulding illustrations in this section are not depicted to actual size. Please contact the distribution center in your area for a more extensive selection of moulding profiles. For downloadable, scalable files of moulding profiles that can be reproduced at actual size, please visit our Web site at [www.hardwoodweb.com](http://www.hardwoodweb.com).

## Window Trim

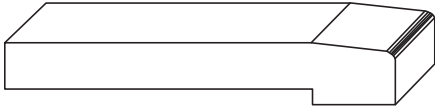

Door Sill  
WCM46-3/4  
1-1/16 x 6-3/4

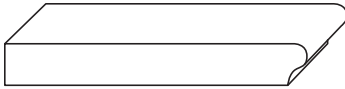

Stool  
WCM39  
11/16 x 5-1/4

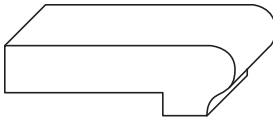

Stool  
WCM1162  
1-1/4 x 4



Stool  
WCM1194  
11/16 x 2-3/4

## T & G Paneling



V-JT Pickwick



Twin V-JT Bead

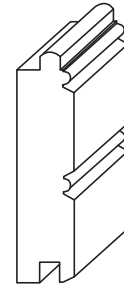

Double Beaded



V-Joint

All paneling profiles are offered tongue-and-groove in 1x4, 1x6 and 1x8, depending on species.

Paneling also offered in two thicknesses:  
9/16" resawn and 3/4" full sawn.

Moulding illustrations in this section are not depicted to actual size. Please contact the distribution center in your area for a more extensive selection of moulding profiles. For downloadable, scalable files of moulding profiles that can be reproduced at actual size, please visit our Web site at [www.hardwoodweb.com](http://www.hardwoodweb.com).

## VENEER-WRAPPED MOULDING



### Veneer-Wrapped Moulding from Contact Industries

Your selection of stylish architectural millwork is virtually limitless when you choose veneer-wrapped mouldings from Contact Industries. We are the exclusive Southeast distributor of this inventive product line, which is designed to provide all the beauty and appeal of solid hardwood moulding, but with customized options that aren't always available with traditional hardwood profiles.

Contact Industries has earned recognition as a leader in profile veneer wrapping, flat veneer lamination and pre-finish technology. Additionally, Contact Industries is FSC-certified for chain of custody and is ISO 9000-2008 certified.

These technologically-advanced moulding products are produced by wrapping a dimensionally stable substrate in defect-free, real wood veneer with color uniformity the full length. Veneer-wrapped mouldings are available in virtually any profile up to 10" wide and 16' long, and are designed to be used just as you would use any moulding profile. They can be combined for built-up moulding applications, or used in traditional applications, such as single-profile base or crown.

### LEED® Credits

Contact Industries custom-designed, veneer-wrapped architectural mouldings and millwork products contribute to green building standards and qualify for LEED® credits in a variety of ways. The following chart shows LEED credits available in various categories.

Core	No Added Urea-Formaldehyde Resin Adhesives	FSC Certified	CARB Compliant	Recycled Content	Veneer/Wrap Material	LEED® Credits Supported
Finger-joint Softwood	YES	Available	NA	None	Any species wood FSC-Certified on request Vinyl film	EQ 4.1 EQ 4.2 MR 5.1 MR 5.2 MR 7
Finger-joint Hardwood	YES	Available	NA	Subject to Availability	Any species wood FSC-Certified on request Vinyl film	EQ 4.1 EQ 4.2 MR 5.1 MR 5.2 MR 7
MDF	YES	Available	YES	100%	Any species wood FSC-Certified on request Vinyl film	EQ 4.4 MR 4.1 MR 4.2 MR 5.1 MR 5.2 MR 7

A selection of case studies which demonstrates the use of these unique mouldings follows. Once you see what you can do with veneer-wrapped mouldings, you'll want to take advantage of their versatility when you plan your next project.



## Bank Approved

*Westsound Bank is located in Sequim, Washington, nestled along the picturesque Strait of Juan de Fuca at the northern end of the Olympic Peninsula.*

When it comes to scrutinizing finances, you can count on banks to be thorough. This case is no exception. Architects for Washington's Westsound Bank specified warm, inviting cherry hardwood ceilings. Luckily, the contractor's construction superintendent recalled an ad for wood paneling that could deliver on both appearance and cost. That's when Contact Industries got the call.

Contact's tongue and groove veneer-wrapped paneling was ideal for the job. Not only did the architects achieve the atmosphere they desired, the builders benefited from the clear, consistent and easy-to-install 16-foot panel lengths. As for the bank president, there was only one thing to say about Contact's lower overall installed cost: approved.



Westsound Bank  
Sequim, WA



INNOVATION SINCE 1946

Distributed exclusively in the Southeast by Hardwoods Incorporated





# PROJECT PROFILE

**PROJECT:** Westsound Bank, Sequim, WA

**Client:** Edensaw Woods  
**Details:** 207 pieces at 198"  
57 pieces at 123"  
4,000 total lineal feet

**PRODUCT:** Wood-wrapped T&G paneling

**Construction:** 1"x6" fingerjoint pine core with cherry hardwood veneer  
**Adhesive:** Type I Hot Melt  
**Test procedures:** Boil test  
**End use:** Ceiling  
**Core:** Finger-jointed pine  
**Face veneer:** Cherry

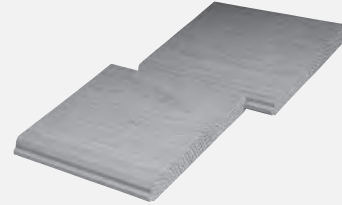

**Contact Industries' Custom Profile-wrapped Products**

Contact offers a full range of profile-wrapped solutions for a wide variety of industries. These include: architectural mouldings; window components; door jambs, stiles and rails; as well as a variety of components for fixture and cabinet manufacturers. Many of these products are custom-designed to meet the specific requirements or requests of the customer. Specifications for Contact's wrapped products:

- Substrate:** Virtually any material, including finger-jointed pine, LVL, MDF, extruded aluminum, or PVC. Substrates are extruded or edge-glued and profiled prior to wrapping.
- Veneer:** Any wood species, including oak, cherry, maple, fir, alder, and a wide variety of exotics. Veneers are fleece-backed; standard thickness is .024". Vinyl, stainable or finished, and impregnated cellulose (film), printed to look indistinguishable from real wood, are also available.
- Size:** Up to 10" wide and 16' lengths (18-footers on request).
- Finishing:** Wood veneers can be pre-finished with stain and/or top coat and an environmentally friendly UV cure.

Some standard moulding profiles are sold through distribution. Call for details.



Contact Industries is Forest Stewardship Council Chain of Custody Certified SCS-COC-001260



Distributed exclusively in the Southeast by Hardwoods Incorporated

Atlanta Location 800 964-7804

Birmingham Location 800 467-4160





## FUNCTION, MEET FORM.

The new fire-rated door frame from Contact Industries allows architects and contractors to comply with the strictest of fire ratings without compromising aesthetics. Contact's innovative technologies can wrap frames in a virtually unlimited assortment of hardwood and softwood veneers, as well as paint-grade and high-pressure laminates, to match doors, casings and interior trim.

The frame's unique composite design incorporates intumescent material directly into the frame itself, offering significant cost savings while maintaining the wall system's ability to achieve the necessary fire rating. Frames are capable of meeting US and UK standards for fire ratings up to 120 minutes, and are available in single- or double-rabbit for single and double openings, as well as communicator frames.



INNOVATION SINCE 1946

Distributed exclusively in the Southeast by Hardwoods Incorporated



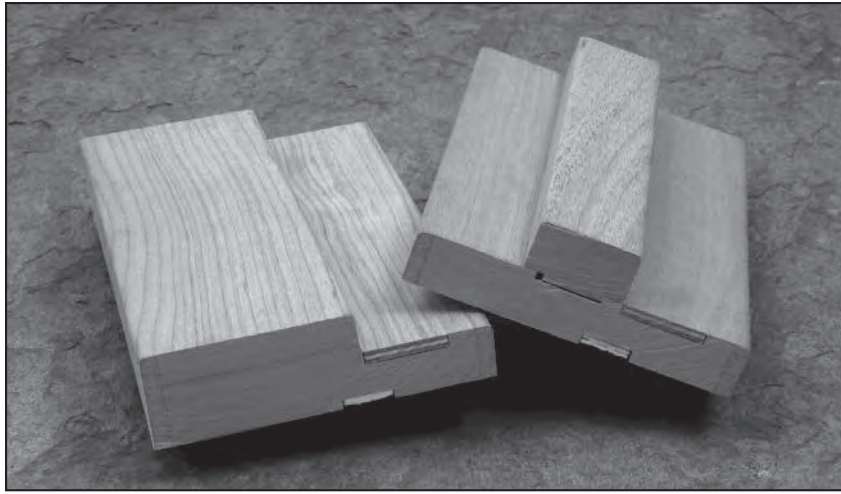
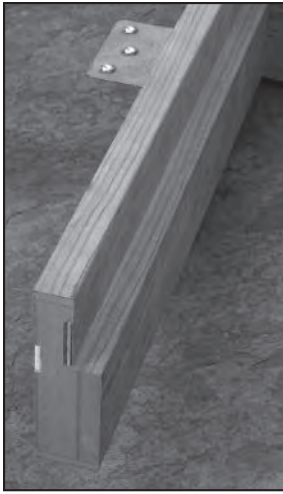

### Features and Benefits:

- Patented frame composition; fire-rated up to 120 minutes
- No special fillers or joint compound required to maintain fire rating
- Can be used with positive pressure or neutral pressure tested doors and hardware
- Available in paint-grade, high-pressure laminate or wood veneer
- Available with factory-applied stains and topcoats, including UV finishing. Versatile finishes allow frames to match entire millwork package.
- Can match virtually any wood veneer species
- Adjustable clip anchorage simplifies installation; no exposed fasteners
- Available as a single-rabbit, double-rabbit, or communicator frame

System Specifications	20-, 45- and 60- Minute positive or Neutral pressure		90- and 120- Minute positive or Neutral pressure	
	MIN	MAX	MIN	MAX
Wall thickness	4 3/4"	None	5"	None
Opening Width, Single Swing	None	Up to 48"	None	Up to 48"
Opening Width, Pairs	None	Up to 84"	None	Up to 84"
Opening Height	None	Up to 96"	None	Up to 96"
Jamb Thickness	7/8"	None	7/8"	None



Distributed exclusively in the Southeast  
by Hardwoods Incorporated

Atlanta Location 800 964-7804

Birmingham Location 800 467-4160



# Six Distribution Centers Serving the Southeast

We are committed to being your natural resource for hardwood lumber, plywood, veneers and a variety of quality cabinet supplies. As an industry leader, we continually upgrade our services and equipment to ensure on-time delivery for every order and the broadest possible offering of remanufacturing services. Six strategic locations throughout the Southeast allow us to provide top-notch service combined with competitively priced products.

Our premium hardwood is air-dried under sheds to guarantee flat, bright lumber. Covered air-drying sheds, computerized kiln controls, variable-speed fans, equalizing and conditioning ensure a consistent, high-quality product.

State-of-the-art computerized systems ensure that inventory is up-to-date and the highest quality standards are maintained in every process, from kiln drying to custom sorting. Please contact one of our six distribution centers for detailed information about product availability, custom orders and lead-times for specialty products.



Members of the Georgia Chapter of the Architectural Woodwork Institute (AWI), Wood Components Manufacturer's Association (WCMA), National Hardwood Lumber Association (NHHLA), the North American Building Material Distribution Association (NBMDA), and the Hardwood Distributors Association (HDA).





**Atlanta Location**

800-964-7804

404-792-0910

**Birmingham**

**Location**

800-467-4160

205-664-0224

**North Georgia**

**Location**

800-421-9686

706-865-4808

**Central Georgia**

**Location**

800-994-2972

706-494-0350

**Clarksville Tennessee**

**Location**

877-989-9663

931-802-2534

**Memphis Tennessee**

**Location**

800-474-4039

901-457-3000

[www.hardwoodweb.com](http://www.hardwoodweb.com)

© June 2010. All rights reserved.

All rights are reserved for the individual owners of registered trade marks and trademarks as indicated.